

GEOMETRY OF WEAK STABILITY BOUNDARIES

E. BELBRUNO[†], M. GIDEA[‡], AND F. TOPPUTO

ABSTRACT. The notion of a weak stability boundary has been successfully used to design low energy trajectories from the Earth to the Moon. The structure of this boundary has been investigated in a number of studies, where partial results have been obtained. We propose a generalization of the weak stability boundary. We prove analytically that, in the context of the planar circular restricted three-body problem, under certain conditions on the mass ratio of the primaries and on the energy, the weak stability boundary about the heavier primary coincides with a branch of the global stable manifold of the Lyapunov orbit about one of the Lagrange points.

1. INTRODUCTION

We consider the planar circular restricted three-body problem for a small mass ratio of the primaries. We give a general definition of the weak stability boundary set in the region of the heavier primary. We consider the global stable manifold of the Lyapunov orbit about the Lagrange point located between the primaries. We prove analytically that, under restrictions on the energy, the weak stability boundary coincides with the branch of the global stable manifold in the region of the heavier primary.

The concept of WSB was introduced in [1, 2] to design low energy transfers from Earth to Moon, and subsequently applied to the rescue of the Japanese mission Hiten in 1991.¹ (See also [3].) A particular feature of the ‘WSB method’ useful for applications is that it allows the capture of a spacecraft into an elliptic orbit about the Moon, with specified eccentricity of the ellipse, and with specified true anomaly at the capture.

There has been considerable work devoted to understand the concept of WSB from the point of view of dynamical systems, and to enhance its applicability (see, e.g., [6, 13, 4, 12]). A remarkable property of the WSB is that, in the context of the planar circular restricted three-body problem, for some range of energies, and under some topological conditions on the hyperbolic invariant manifolds associated to the libration points, the weak stability boundary points coincide with the points on the stable manifolds satisfying some additional conditions. This has been observed numerically in [6], and argued geometrically in [4].

The classical definition of the WSB is as follows: for each radial segment emanating from the Moon, we consider trajectories that leave that segment at the periapsis of an

Key words and phrases. Planar Circular Restricted Three-Body Problem; Weak Stability Boundary; Hyperbolic Invariant Manifolds; Conley’s Isolating Block.

[†] Research of E.B. was partially supported by NASA/AISR grant NNX09AK61G Program of SMD.

[‡] Research of M.G. was partially supported by NSF grant DMS-0635607.

¹The GRAIL mission of NASA, arriving at the Moon on January 1, 2012, is using the same transfer as Hiten [8].

osculating ellipse whose semi-major axis is a part of the radial segment; a trajectory is called weakly n -stable if it makes n full turns around the Moon without going around the Earth, and it has negative Kepler energy when it returns to the radial segment; if the trajectory is weakly $(n-1)$ -stable but fails to be weakly n -stable, it is called weakly n -unstable; the points that make the transition from the weakly n -stable regime to the weakly n -unstable regime are by definition the points of the WSB of order n .

We note that WSB points lie on different Hamiltonian energy levels. Also, the WSB is not an invariant set for the Hamiltonian flow. We remark that, since the stability/instability criteria, as described above, are concerned with the behavior of trajectories for finite time, they inherently introduce ‘artifacts’, i.e., points with very similar trajectories that are categorized differently with respect to these criteria. See [4, 11].

In the present note, we propose a more general definition of the WSB. We remove the condition that the infinitesimal mass leaves the radial segment at the periapsis of an osculating ellipse whose semi-major axis is a part of the radial segment. We remove the condition on negative Kepler energy at the return. We define a point on the radial segment as being weakly n -stable provided that it makes n turns around the primary, such that the distance from the infinitesimal mass to the primary measured along the trajectory does not get bigger than some critical distance. Otherwise the point is redeemed as unstable. (Some of these ideas are also suggested in [11].) The main result of this paper is that the WSB points, which make the transition from the weakly stable to the weakly unstable regime, are the points on the stable manifold of the Lyapunov orbit for the corresponding energy level.

The argument for the main result is analytical, relying on topological arguments and estimates from [5, 10, 9]. For this reason, we deal with the WSB set about the heavier primary (unlike in the WSB original setting).

An interesting aspect of the WSB method is that it uses ‘local’ information on the dynamics, namely the return of trajectories to a surface of section about one of the primaries, to infer some ‘global’ information on the dynamics, namely the existence of trajectories that execute transfers from one primary to the other.

2. BACKGROUND

2.1. The planar circular restricted three-body problem. We consider the planar circular restricted three-body problem (PCRTBP) with the mass ratio of the primaries sufficiently small. The system consists of two mass points P_1, P_2 , called primaries, of masses $m_1 > m_2 > 0$, respectively, that move under mutual Newtonian gravity on circular orbits about their barycenter, and a third point P_3 , of infinitesimal mass, that moves in the same plane as the primaries under their gravitational influence, but without exerting any influence on them. Let $\mu = m_2/(m_1 + m_2)$ be the relative mass ratio of m_2 . In the sequel, we will assume that $0 < \mu < 1$ is very small, which will be made precise later.

It is customary to study the motion of the infinitesimal mass in a co-rotating system of coordinates (x, y) that rotates with the primaries. Relative to this system, P_1 is positioned at $(\mu, 0)$ and P_2 is positioned at $(-1 + \mu, 0)$. After some rescaling, the

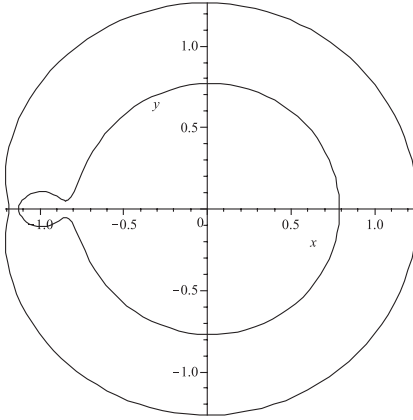
 FIGURE 1. A Hill's region, $H \in (H(L_1), H(L_2))$.

equations of motions are given by

$$(2.1) \quad \ddot{x} - 2\dot{y} = \frac{\partial \omega}{\partial x}, \quad \ddot{y} + 2\dot{x} = \frac{\partial \omega}{\partial y},$$

where the effective potential ω is given by

$$(2.2) \quad \omega(x, y) = \frac{1}{2}(x^2 + y^2) + \frac{1 - \mu}{r_1} + \frac{\mu}{r_2} + \frac{1}{2}\mu(1 - \mu),$$

with $r_1 = ((x - \mu)^2 + y^2)^{1/2}$, $r_2 = ((x + 1 - \mu)^2 + y^2)^{1/2}$.

The equations of motion can be described by a Hamiltonian system given by the following Hamiltonian (energy function):

$$(2.3) \quad H(x, y, p_x, p_y) = \frac{1}{2}((p_x + y)^2 + (p_y - x)^2) - \omega(x, y),$$

where $\dot{x} = p_x + y$ and $\dot{y} = p_y - x$.

For each fixed value H of the Hamiltonian, the energy hypersurface M_H is a non-compact 3-dimensional manifold in the 4-dimensional phase space. The projection of the energy hypersurface onto the configuration space (x, y) is called a Hill's region, and its boundary is a zero velocity curve. See Fig. 1. Every trajectory is confined to the Hill's region corresponding to the energy level of that trajectory.

The equilibrium points of the differential equations (2.1) are given by the critical points of ω . There are five equilibrium points for this problem: three of them, L_1 , L_2 and L_3 , are collinear with the primaries (where L_1 is between L_2 and L_3), while the other two, L_4, L_5 , form equilateral triangles with the primaries. The distance from L_1 to P_2 is given by the only positive solution x_+ to Euler's quintic equation

$$(2.4) \quad x^5 - (3 - \mu)x^4 + (3 - 2\mu)x^3 - \mu x^2 + 2\mu x - \mu = 0,$$

and so the distance from L_1 to P_1 is $1 - x_+$.

The values $H(L_i)$ of the Hamiltonian (2.3) at the points L_i , $i = 1, \dots, 5$, satisfy $H(L_5) = H(L_4) > H(L_3) > H(L_2) > H(L_1)$. For $H < H(L_1)$, the Hill's region has three components: two bounded components, one about P_1 and the other about P_2 ,

and a third component which is unbounded. For $H \in (H(L_1), H(L_2))$, the Hill's region has two components, one bounded, which is topologically equivalent to the connected sum of the two bounded components from the case $H < H(L_1)$, and the other one unbounded (Fig. 1).

The linearized stability of the equilibrium point L_1 is of saddle-center type, with the linearized equations possessing a pair of non-zero real eigenvalues $\pm\lambda$, and a pair of complex conjugate, purely imaginary eigenvalues $\pm i\nu$. For each $H \gtrsim H(L_1)$, near the equilibrium point L_1 there exists a unique hyperbolic periodic orbit γ_H , referred as a Lyapunov orbit. This orbit has 2-dimensional stable and unstable manifolds $W^s(\gamma_H)$, $W^u(\gamma_H)$, respectively, that are locally diffeomorphic to 2-dimensional cylinders. These manifolds have the following separatrix property: when restricted to a compact neighborhood $B_H(a, b)$ of γ_H in the energy hypersurface M_H , of the type $B_H(a, b) = \{a \leq x \leq b\}$, with $a < x_{L_1} < b$ sufficiently close to x_{L_1} , each of the manifolds $W^s(\gamma_H)$, $W^u(\gamma_H)$ separates $B_H(a, b)$ into two connected components.

2.2. Conley's isolating block. Let $\phi : M \times \mathbb{R} \rightarrow M$ be a C^1 -flow on a C^1 -differentiable manifold M . Given a compact submanifold with boundary $B \subseteq M$, with $\dim(B) = \dim(M)$, we define

$$\begin{aligned} B^- &= \{p \in \partial B \mid \exists \varepsilon > 0 \text{ s.t. } \phi_{(0, \varepsilon)}(p) \cap B = \emptyset\}, \\ B^+ &= \{p \in \partial B \mid \exists \varepsilon > 0 \text{ s.t. } \phi_{(-\varepsilon, 0)}(p) \cap B = \emptyset\}, \\ B^0 &= \{p \in \partial B \mid \phi_t \text{ is tangent to } \partial B \text{ at } p\}. \end{aligned}$$

We obviously have $\partial B = B^0 \cup B^- \cup B^+$. We call B^- the exit set and B^+ the entry set of B .

An open set V is called an isolating neighborhood for the flow if ∂V contains no orbit of ϕ . An invariant set S for the flow ϕ is an isolated invariant set if there exists an isolating neighborhood V for the flow such that S is the maximal invariant set in V . The compact submanifold B is called an isolating block for the flow ϕ provided that:

- (i) $B^- \cap B^+ = B^0$,
- (ii) B^0 is a smooth submanifold of ∂B of codimension 1, and, consequently, B^- , B^+ are submanifolds with common boundary B^0 .

The interior of an isolating block is an isolating neighborhood and so determines an isolated invariant set, possibly empty.

In the PCRTBP, Conley has constructed an isolating block around L_1 that can be used to study the nearby dynamics. Consider the part of the Hill's region which satisfies $a \leq x \leq b$, where (a, b) contains the x -coordinate x_{L_1} of L_1 . This set determines a "dynamical channel" which allows for the transit of trajectories between the P_1 and P_2 regions. The lift $B_H = B_H(a, b)$ of this set to the energy hypersurface, where a, b are chosen close to x_{L_1} , is Conley's isolating block. Geometrically, this is a 3-dimensional manifold with boundary ∂B_H consisting of the set of points in the energy hypersurface that projects onto $x = a$ and $x = b$ in the configuration space. It is diffeomorphic to the product of a line segment with a two sphere, $B_H \approx [a, b] \times S^2$, and its boundary ∂B_H is diffeomorphic to the union of two 2-spheres, $\partial B_H = B_{H,a} \cup B_{H,b} \approx (\{a\} \times S^2) \cup (\{b\} \times S^2)$.

The isolating block conditions in this case are that every trajectory intersecting ∂B tangentially must lie outside of B_H both before and after the intersection, that is, if $x(t) = a$ and $\dot{x}(t) = 0$ then $\ddot{x}(t) < 0$ and if $x(t) = b$, and $\dot{x}(t) = 0$ then $\ddot{x}(t) > 0$. So we have

$$\begin{aligned} B_H^0 &= \{(x, y, \dot{x}, \dot{y}) \in \partial B_H \mid x(t) = a \text{ or } x(t) = b \text{ and } \dot{x}(t) = 0\}, \\ B_H^- &= \{(x, y, \dot{x}, \dot{y}) \in \partial B_H \mid x(t) = a \text{ and } \dot{x}(t) < 0, \text{ or } x(t) = b \text{ and } \dot{x}(t) > 0\}, \\ B_H^+ &= \{(x, y, \dot{x}, \dot{y}) \in \partial B_H \mid x(t) = a \text{ and } \dot{x}(t) > 0, \text{ or } x(t) = b \text{ and } \dot{x}(t) < 0\}. \end{aligned}$$

For each component of ∂B_H , the exit and entry sets determine a pair of disjoint open 2-dimensional topological disks, which we denote as follows: $B_{H,a}^-, B_{H,b}^-$ are the exit sets of the boundary components $B_{H,a}, B_{H,b}$, respectively, and $B_{H,a}^+, B_{H,b}^+$ are the entry sets of the boundary components $B_{H,a}, B_{H,b}$, respectively. The complement in $B_{H,b}$ of $B_{H,b}^- \cup B_{H,b}^+$ is the set $B_{H,b}^0 = B_H^0 \cap \{x = b\}$. A similar statement holds for $B_{H,a}$.

The exit and entry sets are further broken up into components with dynamical roles. The set $B_{H,b}^+$ is the union of three sets, a spherical cap $B_{H,b}^{+,a}$, corresponding to trajectories that enter the block B_H through the entry part of $B_{H,b}$ and later leave the block through the exit part of $B_{H,a}$, a spherical zone $B_{H,b}^{+,b}$, corresponding to trajectories that enter the block B_H through the entry part of $B_{H,b}$ and leave the block through the exit part of $B_{H,b}$, and a topological circle separating them, corresponding to the intersection of $W^s(\gamma_H)$ with $B_{H,b}$. Similarly, $B_{H,b}^- = B_{H,b}^{-,a} \cup B_{H,b}^{-,b} \cup (B_{H,b} \cap W^u(\gamma_H))$, where the notation is analogous to the above. There is a similar decomposition for the entry and exit set components of $B_{H,a}$. See Fig. 2.

Later in the paper, we will use the following fact, which is a consequence of the above discussion. There are three possible behaviors for trajectories that start from the P_1 -region and enter the isolating block:

- (i) Trajectories enter the block through $B_{H,b}^{+,a}$, exit the block through $B_{H,a}^{-,b}$, and so they execute a transfer from the P_1 -region to the P_2 -region.
- (ii) Trajectories enter the block through $B_{H,b}^{+,b}$, exit the block through $B_{H,b}^{-,b}$, and so they do not transfer to the P_2 -region.
- (iii) Trajectories enter the block through $B_{H,b} \cap W^s(\gamma_H)$ and are forward asymptotic to γ_H , and so they never leave the block.

For further details on this subsection, see [5].

2.3. Hyperbolic invariant manifolds. The geometry of the hyperbolic invariant manifolds can be described analytically inside the P_1 -region, for some range of energies and mass ratios, following some results from [10, 9].

First, there exists an open set O_1 in the (μ, H) -parameter plane, with $0 < \mu \ll 1$ and $H \gtrsim H(L_1)$ such that, for $(\mu, H) \in O_1$, the following hold:

- (i) The energy hypersurface M_H contains an invariant 2-torus \mathcal{T}_H separating P_1 from L_1 .
- (ii) There exist $a < x_{L_1} < b$ such that the flow inside the isolating block $B_H = B_H(a, b)$ is conjugate to the linearized flow.

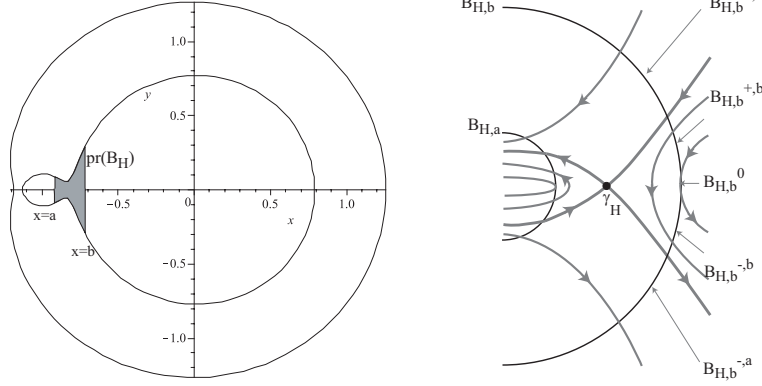

FIGURE 2. (a) Projection of Conley's isolating block onto configuration space. (b) Schematic representation of the dynamics across Conley's isolating block.

- (iii) In the region \mathcal{N}_H in M_H bounded by \mathcal{T}_H and $B_{H,b}$, the longitudinal angular coordinate θ is increasing along trajectories.

Second, for all $0 < \mu \ll 1$ sufficiently small, the (x, y) -projections of the branches of $W^u(L_1), W^s(L_1)$ inside the P_1 -region have the following properties:

- (iv) The distance d to the zero velocity curve, and the angular coordinate θ satisfy the following estimates:

$$(2.5) \quad d = \mu^{1/3} \left(\frac{2}{3}N - 3^{1/6} + M \cos t + o(1) \right),$$

$$(2.6) \quad \theta = -\pi + \mu^{1/3} (Nt + 2M \sin t + o(1)),$$

where M, N are constants, the parameter t means the physical time measured from a suitable origin, and $o(1) \rightarrow 0$ when $\mu \rightarrow 0$ uniformly in t as $t = O(\mu^{-1/3})$. These expressions hold true outside B_H .

- (v) There exists an open set $O_2 \subseteq O_1$ in the (μ, H) -parameter plane, with $0 < \mu \ll 1$ and $H \gtrsim H(L_1)$ such that, for $(\mu, H) \in O_2$, the (x, y) -projections of the branches of $W^u(\gamma_H), W^s(\gamma_H)$ inside the P_1 -region satisfy estimates similar to (2.5) and (2.6). That is, these invariant manifolds turn around P_1 in the region \mathcal{N}_H bounded by the torus \mathcal{T}_H and the boundary component $B_{H,b}$ of the isolating block B_H . Moreover, there exists a sequence of mass ratios μ_k for which $W^u(\gamma_H)$ and $W^s(\gamma_H)$ have symmetric transverse intersections, provided $(\mu_k, H) \in O_2$.

The geometry of the hyperbolic invariant manifolds for the range of parameters considered above allows to extend the separatrix property of these manifolds from the local case, as described in Subsection 2.1, to the global case. For as long as the stable and unstable manifolds do not intersect each other, the cuts of these manifolds with a surface of section are topological circles. If a point is inside the i -th cut $\Gamma_{\theta_0, i}^s(\gamma_H)$ made by the stable manifold $W^s(\gamma_H)$ with the surface of section S_{θ_0} , which is assumed to be a topological circle, then the forward trajectory of that point stays inside the

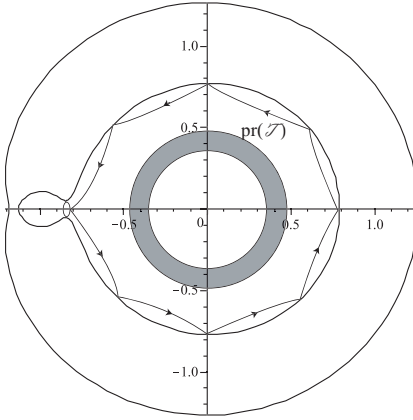

FIGURE 3. Projection of McGehee's separating torus onto configuration space, and trajectory near the zero velocity curve.

cylinder bounded by $W^s(\gamma_H)$ in M_H for i -turns and transfers from the P_1 -region to the P_2 -region afterwards. If a point in S_{θ_0} is outside the i -th cut $\Gamma_{\theta_0,i}^s(\gamma_H)$, then its forward trajectory stays inside the P_1 -region for at least $(i+1)$ -turns. A similar statement holds for the cuts made by the unstable manifold and backwards trajectories.

If the stable and unstable manifolds intersect, say $\Gamma_{\theta_0,i}^s(\gamma_H)$ intersects $\Gamma_{\theta_0,j}^u(\gamma_H)$, then the intersection points are homoclinic points that make $(i+j)$ -turns about P_1 , and some future cuts of the invariant manifolds cease to be topological circles. For example, $\Gamma_{\theta_0,i+j}^s(\gamma_H)$ is a finite union of open curve segments whose endpoints wind asymptotically towards $\Gamma_{\theta_0,i}^s(\gamma_H)$. Due to the asymptotic behavior of the endpoints, each of these open curves divides S_{θ_0} into transfer and non-transfer orbits. Thus, the separatrix property extends to the case when the cuts of the hyperbolic invariant manifolds cease being topological circles. See [7, 4].

There are no analogues of the above analytical results for the P_2 -region about the lighter mass.

2.4. Equations of motion relative to polar coordinates. We recall the relations between the motion of the infinitesimal mass P_3 relative to the barycentric rotating coordinates (x, y, \dot{x}, \dot{y}) , relative to the polar coordinates $(r, \theta, \dot{r}, \dot{\theta})$ about P_1 , and relative to the classical orbital elements (a, e, ϕ, τ) about P_1 .

The relation between barycentric and polar coordinate is $r = ((x - \mu)^2 + y^2)^{1/2}$ and $\tan \theta = y/(x - \mu)$.

The orbital elements are characterized by the semi-major axis a of an ellipse with a focus at P_1 , the ellipse eccentricity $e \in [0, 1)$, the argument of the periapsis $\phi \in [0, 2\pi]$,

and the true anomaly $\tau \in [0, 2\pi]$. We have the following coordinate transformations

$$(2.7) \quad \begin{aligned} x &= r \cos(\phi + \tau) + \mu, \\ y &= r \sin(\phi + \tau), \\ \dot{x} &= \dot{r} \cos(\phi + \tau) - r\dot{\tau} \sin(\phi + \tau) + r \sin(\phi + \tau), \\ \dot{y} &= \dot{r} \sin(\phi + \tau) + r\dot{\tau} \cos(\phi + \tau) - r \cos(\phi + \tau), \end{aligned}$$

and the following formulas

$$(2.8) \quad \begin{aligned} r &= \frac{a(1 - e^2)}{1 + e \cos \tau}, \\ \dot{r} &= \frac{ae(1 - e^2)\dot{\tau} \sin \tau}{(1 + e \cos \tau)^2}, \\ \theta &= \phi + \tau, \\ \dot{\theta} &= \dot{\tau} = \frac{\sqrt{a(1 - e^2)(1 - \mu)}}{r^2}. \end{aligned}$$

The Hamiltonian function in polar coordinates is given by

$$(2.9) \quad H(r, p_r, \theta, p_\theta) = \frac{1}{2}(p_r^2 + \frac{1}{r^2}\theta^2) - p_\theta + \mu r \cos \theta + \omega(r, p_r, \theta, p_\theta),$$

where the canonical momenta are given by

$$p_r = \dot{r}, \quad p_\theta = r^2(\dot{\theta} + 1).$$

Note that the conservation of energy implies that the initial position (r, θ) relative to P_1 and the initial radial velocity \dot{r} uniquely determine a trajectory, up to a choice of a sign for $\dot{\theta}$. Suppose that we know the initial data (r, \dot{r}, θ) on a trajectory. Using (2.8), the eccentricity of the osculating ellipse to this trajectory at the initial point uniquely determines the trajectory, and hence its energy. This implicitly defines ϕ and τ . Conversely, if we have a trajectory for which the initial angle coordinate θ , the initial angular velocity \dot{r} , and the eccentricity of the osculating ellipse e at the initial condition are fixed, then the energy level H of the trajectory uniquely determines its initial value of r .

3. WEAK STABILITY BOUNDARY

We consider the system of polar coordinates (r, θ) about P_1 as above, and we let $H(r, \dot{r}, \theta, \dot{\theta})$ be the Hamiltonian relative to this coordinate system. As discussed above, the energy is also uniquely determined by the (r, \dot{r}, θ, e) -data, where e is the eccentricity of the osculating ellipse at the initial point. We consider a Poincaré section through P_1 that makes an angle θ_0 with the x -axis, which is given by

$$S_{\theta_0} = \{(r, \dot{r}, \theta, \dot{\theta}) \mid \theta = \theta_0, \dot{\theta} > 0\}.$$

Let l_{θ_0} denote the radial segment obtained as the intersection of S_{θ_0} with the (x, y) -space. Any trajectory that meets S_{θ_0} transversally is uniquely determined by the (r, \dot{r}) -coordinates of the intersection point, as the θ -coordinate equals θ_0 in this section, and the $\dot{\theta}$ -coordinate can be solved uniquely from the energy condition $H(r, \dot{r}, \theta, \dot{\theta}) = H$, provided $\dot{\theta} > 0$.

Consider a trajectory with the initial condition $z_0 = z_0(r_0, \dot{r}_0, \theta_0, e_0)$ with initial position $r(0) = r_0$, $\theta(0) = \theta_0$, initial radial velocity $\dot{r}(0) = \dot{r}_0$, and $\dot{\theta}(0) > 0$, for which the osculating ellipse at the initial point has eccentricity e_0 . We keep the values of \dot{r}_0, θ_0, e_0 fixed and investigate the change of behavior of the trajectories when r_0 changes. Note that different initial values of r_0 yield different energies H_0 .

Fix a value of μ sufficiently small for which there exists an open range of energies $(H(L_1), H^*)$ with $(\mu, H) \in O_2$ for each $H \in (H(L_1), H^*)$, as in Subsection 2.3. For this range of energies the estimates (2.5) are valid. Fix $a < x_{L_1} < b$ such that $B_H(a, b)$ is an isolating block for all $H \in (H(L_1), H^*)$. Let y_b be the supremum of the y -coordinates on the segment $x = b$ inside the Hill's regions for $H \in (H(L_1), H^*)$. Define $\theta_1 = \arctan(y_b/(\mu - b))$. Let D_1 be the distance from P_1 to $x = a$, that is $D_1 = \mu - a$.

Fix $H \in (H(L_1), H^*)$ and consider the projection $\text{pr}_{(x,y)}(\mathcal{N}_H)$ of \mathcal{N}_H onto the (x, y) -configuration plane. For each angle coordinate $\theta \in [0, 2\pi]$, there exists a well defined interval $(r_1(H, \theta), r_2(H, \theta))$ such that $(r, \theta) \in \text{pr}_{(x,y)}(\mathcal{N}_H)$ if and only if $r \in (r_1(H, \theta), r_2(H, \theta))$. For each trajectory point $(r, \theta) \in \text{pr}_{(x,y)}(\mathcal{N}_H)$ there exists a set of admissible values of the radial velocity \dot{r} and of the eccentricity of the osculating ellipse e corresponding to the trajectory at that point. When we let H vary in $(H(L_1), H^*)$, then for each $\theta \in [0, 2\pi]$, we obtain an open set of admissible values of (\dot{r}, e) corresponding to all trajectories for all of these energy levels.

We fix an angle θ_0 and a pair of admissible values (\dot{r}_0, e_0) . Since the energy H is uniquely determined by the data $(r_0, \dot{r}_0, \theta_0, e_0)$, there exists an open set $\mathcal{R}(\dot{r}_0, \theta_0, e_0) \subseteq (r_1(H, \theta), r_2(H, \theta))$ of r_0 -values such that $H_0 = H(r_0, \dot{r}_0, \theta_0, e_0) \in (H(L_1), H^*)$ provided $r_0 \in \mathcal{R}(\dot{r}_0, \theta_0, e_0)$. In the next definition, we will consider trajectories with initial points z_0 lying on the radial segment l_{θ_0} . We will restrict to values of r_0 in the set $\mathcal{R}(\dot{r}_0, \theta_0, e_0)$.

Definition 3.1. We say that a forward trajectory with initial point $z_0 = z_0(r_0, \theta_0)$ in l_{θ_0} , initial radial velocity \dot{r}_0 and initial eccentricity of the osculating ellipse e_0 , is weakly n -stable provided that it turns n -times around P_1 , with all intersections with l_{θ_0} being transverse, and such that the distance to P_1 is always less than D_1 . If the trajectory is weakly $(n - 1)$ -stable but fails to be weakly n -stable, we say that the trajectory is weakly n -unstable.

The conditions on the parameters assumed for the Definition 3.1 are imposed in order to define the critical distance D_1 in a consistent way for the whole range of energy values $H \in (H(L_1), H^*)$. We recall that in the classical definition of the WSB, a trajectory is called n -stable if it turns n -times around P_1 , without turning around P_2 ; in that case one can consider the distance from P_1 to P_2 as the critical distance.

We note that the transversality requirement in Definition 3.1, on the intersections of the trajectory of the infinitesimal mass with l_{θ_0} , implies that weak n -stability is an open condition, that is, if a trajectory starting at some $z_0 = (r_0, \dot{r}_0, \theta_0, e_0)$ is weakly n -stable, then all trajectory starting inside some domain of the type

$$(r, \dot{r}, \theta, e) \in (r_0 - \varepsilon, r_0 + \varepsilon) \times (\dot{r}_0 - \varepsilon, \dot{r}_0 + \varepsilon) \times (\theta_0 - \varepsilon, \theta_0 + \varepsilon) \times (e_0 - \varepsilon, e_0 + \varepsilon)$$

with $\varepsilon > 0$ sufficiently small, are also weakly n -stable.

Thus we obtain the following set of weakly stable points in the phase space

$$\mathcal{W}_n = \{z_0(r_0, \dot{r}_0, \theta_0, e_0) \mid z_0 \text{ is weakly } n\text{-stable relative to } l_{\theta_0}, \theta_0 \in [0, 2\pi]\}.$$

Due to the open conditions on the n -stable trajectories, the set \mathcal{W}_n is an open set of points in the phase space. If we fix the parameters \dot{r}_0 , θ_0 and e_0 , then we obtain an open set $\mathcal{W}_n(\dot{r}_0, \theta_0, e_0)$ in l_{θ_0} , which is a countable union of disjoint open intervals

$$(3.1) \quad \mathcal{W}_n(\dot{r}_0, \theta_0, e_0) = \bigcup_{k \geq 1} (r_{2k-1}, r_{2k}).$$

The points of the type r_{2k-1}, r_{2k} at the ends of these intervals are weakly n -unstable.

Definition 3.2. The WSB of order n , denoted \mathcal{W}_n^* , is the set of all points $r^*(r_0, \dot{r}_0, \theta_0, e_0)$ that are at the boundary of the set of the weakly n -stable points, i.e.,

$$\mathcal{W}_n^* = \partial \mathcal{W}_n.$$

We also denote by $\mathcal{W}_n^*(\dot{r}_0, \theta_0, e_0)$ the set of WSB points on the radial segment l_{θ_0} of fixed parameters \dot{r}_0 and e_0 . Thus, the WSB set $\mathcal{W}_n^*(\dot{r}_0, \theta_0, e_0)$ contains the closure of the set of all points of the type r_{2k-1}, r_{2k} , which are the endpoints of the intervals of weakly n -stable points within each radial segment l_{θ_0} as in (3.1).

The main result of the paper says that, if we restrict to some angle range of θ_0 outside the angle sector $[\pi - \theta_1, \pi + \theta_1]$, where θ_1 is defined as above, then the WSB set is completely determined by the stable manifolds of Lyapunov orbits. To state this result, we have to adopt a convention on how to count the number of cuts made by the stable manifold with a surface of section S_{θ_0} . We label a cut made by the stable manifold $W^s(\gamma_{H_0})$ with S_{θ_0} as the i -th cut provided that the net change $\Delta\theta$ of the angle θ along all trajectories starting from S_{θ_0} and ending asymptotically at γ_{H_0} satisfies $2i\pi \leq \Delta\theta < 2(i+1)\pi$. Note that as long as $\theta_0 \notin [\pi - \theta_1, \pi + \theta_1]$ there is no ambiguity about the labeling of the cuts with the section S_{θ_0} .

Theorem 3.3. *Fix a pair of admissible values (\dot{r}_0, e_0) as defined above. Assume $\theta_0 \in (-\pi + \theta_1, \pi - \theta_1)$, where θ_1 is defined as above. Then a point $z_0 = z_0(r_0, \dot{r}_0, \theta_0, e_0)$, with $r_0 \in \mathcal{R}(\dot{r}_0, \theta_0, e_0)$, is in $\mathcal{W}_n^*(\dot{r}_0, \theta_0, e_0)$ if and only if z_0 lies on the $(n-1)$ -st cut $\Gamma_{\theta_0, n-1}^s(\gamma_{H_0})$ of the stable manifold $W^s(\gamma_{H_0})$ with the surface of section S_{θ_0} , where H_0 is the energy level corresponding to z_0 .*

The restrictions imposed on the parameters in Theorem 3.3 are needed to apply the analytical arguments from Subsection 2.3. It is nevertheless shown in [4] that the WSB overlaps with some subset of the stable manifold of the Lyapunov orbit under much weaker conditions, provided that the hyperbolic invariant manifolds satisfy some topological condition (they turn around the primaries for a long enough time, without colliding with the primaries). Moreover, in [4] a wider energy range is considered, in which case the WSB is identified with a subset of the union of the stable manifolds of the Lyapunov orbits about L_1 and about L_2 . The situation described by Theorem 3.3 is just a special case when the required topological conditions can be verified analytically.

Now we explain the relation between WSB and hyperbolic invariant manifolds in a more concrete way. Assume that we fix some energy level $H_0 \in (H(L_1), H^*)$. We generate the stable manifold of the Lyapunov orbit γ_{H_0} , and we count the successive cuts made by the stable manifold with some Poincaré surface of section S_{θ_0} . Let z_0 be a point on the $(n-1)$ -st cut $\Gamma_{\theta_0, n-1}^s(\gamma_{H_0})$ of $W^s(\gamma_{H_0})$ with S_{θ_0} . Let \dot{r}_0 be the radial velocity at z_0 , and e_0 the eccentricity of the osculating ellipse at z_0 . Then the point z_0

is in the WSB set $\mathcal{W}_n^*(r_0, \theta_0, e_0)$. Moreover, every WSB point can be obtained in this way.

4. PROOF OF THE MAIN RESULT

Due to the angle restriction $\theta_0 \in (-\pi + \theta_1, \pi - \theta_1)$, in Theorem 3.3, we restrict to the following set of weakly n -stable points

$$\tilde{\mathcal{W}}_n = \{z_0(r_0, \dot{r}_0, \theta_0, e_0) \mid z_0 \text{ is weakly } n\text{-stable relative to } l_{\theta_0}, \theta_0 \in (-\pi + \theta_1, \pi - \theta_1)\}.$$

Since the n -stability is an open condition and the angle range $(-\pi + \theta_1, \pi - \theta_1)$ is also open, the set $\tilde{\mathcal{W}}_n$ is an open set in the phase space.

We prove that a point $z_0 = z_0(r_0, \dot{r}_0, \theta_0, e_0)$ is in $\tilde{\mathcal{W}}_n^*$ if and only if it is in the $(n-1)$ -st cut $\Gamma_{\theta_0, n-1}^s(\gamma_{H_0})$ made by the stable manifold $W^s(\gamma_{H_0})$ with S_{θ_0} , where H_0 is the energy level corresponding to z_0 . For this, we first show that z_0 is a weakly n -stable point on l_{θ_0} if and only if it is outside the domain in S_{θ_0} bounded by $\Gamma_{\theta_0, n-1}^s(\gamma_{H_0})$, and is weakly n -unstable if and only if it is inside the domain in S_{θ_0} bounded by $\Gamma_{\theta_0, n-1}^s(\gamma_{H_0})$.

First, we show that the points inside the cylinder bounded by the stable manifold are weakly unstable. Let $z_0 = z_0(r_0, \dot{r}_0, \theta_0, e_0)$ be a point in l_{θ_0} . Then (2.9) gives the value H_0 of the energy of the trajectory with initial condition z_0 . Assume that z_0 is inside the domain in S_{θ_0} bounded by $\Gamma_{\theta_0, n-1}^s(\gamma_{H_0})$. By the separatrix property from Subsection 2.3 the trajectory turns counterclockwise precisely $(n-1)$ -times inside the domain \mathcal{N}_{H_0} , while staying inside the region of the cylinder bounded by $W^s(\gamma_{H_0})$, enters the isolating block B_{H_0} through the entry set region $B_{H_0, b}^{+, a}$, crosses the block and exits it through the exit set region $B_{H_0, a}^{-, b}$. When the trajectory leaves the block B_{H_0} , the distance from P_1 is bigger than D_1 . Since the trajectory achieves a distance to P_1 bigger than the threshold value prior to completing an n -th turn around P_1 , the trajectory is weakly n -unstable.

Second, we show that the points outside the cylinder bounded by the stable manifold are weakly stable. Assume that z_0 is outside the domain in S_{θ_0} bounded by $\Gamma_{\theta_0, n-1}^s(\gamma_{H_0})$. By the separatrix property from Subsection 2.3 the trajectory will turn counterclockwise inside the domain \mathcal{N}_{H_0} and will keep staying outside the region of the cylinder bounded by $W^s(\gamma_{H_0})$ for at least n turns. If the trajectory leaves the domain \mathcal{N}_{H_0} , it has to meet the block B_{H_0} at $B_{H_0, a}^0$ or at $B_{H_0, b}^{+, b}$. In the first case, the trajectory bounces back to the domain \mathcal{N}_{H_0} and it continues its counterclockwise motion about P_1 . In the second case, it cannot leave the block B_{H_0} through $B_{H_0, a}$, since only the points that are inside the cylinder bounded by $W^s(\gamma_{H_0})$ can do that; it cannot remain inside the block B_{H_0} for all future times since only the points on $W^s(\gamma_{H_0})$ have this property; hence, it has to leave B_{H_0} through the exit set region $B_{H_0, b}^{-, b}$, and to go back to the domain \mathcal{N}_{H_0} . The time spent by the trajectory inside the block B_{H_0} does not affect the count of turns about P_1 . Since z_0 is outside the cut $\Gamma_{\theta_0, n-1}^s(\gamma_{H_0})$, the trajectory cannot leave the P_1 -region after only $(n-1)$ -turns, so it turns around P_1 for at least n -turns. Thus the trajectory is weakly n -stable.

Now, we prove the statement of the main theorem.

First, assume that z_0 is in $\Gamma_{\theta_0, n-1}^s(\gamma_{H_0})$. Its forward trajectory turns $(n-1)$ -times around P_1 and then approaches asymptotically γ_{H_0} . Thus the trajectory is weakly n -unstable. To show that z_0 is an WSB point it is sufficient to prove that there exists a sequence $(z_0^k)_{k \geq 1}$ with $z_0^k \in \tilde{\mathcal{W}}_n$ and $z_0^k \rightarrow z_0$ as $k \rightarrow \infty$. Take a small 4-dimensional open ball \mathcal{U} around z_0 in the phase space. Let $T > 0$ be such that the time- T map ϕ_T of the Hamiltonian flow takes z_0 to a point in $B_{H_0, b}$, where $H_0 = H(z_0)$. The image $\phi_T(\mathcal{U})$ of \mathcal{U} by ϕ_T is a 4-dimensional open topological ball about $\phi_T(z_0)$. We intersect $\phi_T(\mathcal{U})$ with the 4-dimensional submanifold with boundary $\bigcup_{H \in (H(L_1), H^*)} B_H$. The ball $\phi_T(\mathcal{U})$ has non-empty intersection with $\bigcup_{H \in (H(L_1), H^*)} B_{H, b}^{+, b}$. These intersection points yield weakly n -stable trajectories. Thus $\phi_T(\mathcal{U}) \cap \bigcup_{H \in (H(L_1), H^*)} B_H$ contains a 4-dimensional open, topological ball \mathcal{V} , which contains $\phi_T(z_0)$ on its boundary, consisting of points that correspond to weakly n -stable trajectories, i.e., those trajectories that return to the P_1 region for at least one extra turn about P_1 .

Now consider the set $\phi_{-T}(\mathcal{V})$. This is a 4-dimensional open, topological ball in \mathcal{U} that contains z_0 on its boundary. There exist θ' arbitrarily close to θ_0 such that the intersection $\phi_{-T}(\mathcal{V}) \cap S_{\theta'}$ is a non-empty open set. All points $z' \in \phi_{-T}(\mathcal{V}) \cap S_{\theta'}$ are weakly n -stable points. We note that these points may not lie on l_{θ_0} , nor on the same energy level as z_0 ; they can also have the eccentricity of the osculating ellipse different from e_0 . Thus, arbitrarily near z_0 one can always find weakly n -stable points, and since z_0 itself is weakly n -unstable, it follows that $z_0 \in \partial \tilde{\mathcal{W}}_n = \tilde{\mathcal{W}}_n^*$.

Second, assume that $z_0 \in \tilde{\mathcal{W}}_n^*(\dot{r}_0, \theta_0, e_0)$. Then there exists a sequence of points $(z_0^k)_{k \geq 1}$ on $l(\theta_0)$ such that z_0^k is weakly n -stable and $z_0^k \rightarrow z_0$ as $k \rightarrow \infty$. From the above, we know that the weakly n -stable points are those inside the cylinder bounded by the stable manifold. Thus, there exists a corresponding sequence of stable manifold cuts $\Gamma_{\theta_0, n-1}^s(\gamma_{H_k})$ where $H_k = H(z_0^k)$, such that z_0^k is inside the region in S_{θ_0} bounded by $\Gamma_{\theta_0, n-1}^s(\gamma_{H_k})$. Since $z_0^k \rightarrow z_0$ it follows that $H(z_0^k) \rightarrow H(z_0) = H_0$ as $k \rightarrow \infty$. The stable manifold cuts also depend continuously on the energy, so $\Gamma_{\theta_0, n-1}^s(\gamma_{H_k})$ approaches $\Gamma_{\theta_0, n-1}^s(\gamma_{H_0})$ as $k \rightarrow \infty$. Hence $z_0 \in \Gamma_{\theta_0, n-1}^s(\gamma_{H_0})$.

Through double inclusion, we conclude that

$$z_0 \in \tilde{\mathcal{W}}_n^*(\dot{r}_0, \theta_0, e_0) \text{ if and only if } z_0 \in \Gamma_{\theta_0, n-1}^s(\gamma_{H_0}).$$

5. CONCLUDING REMARKS

We compare the invariant manifold method with the WSB method. The invariant manifold method is based on identifying geometric objects that serve as building blocks that organize the global dynamics: equilibrium points, periodic orbits, and their stable and unstable invariant manifolds, if they exist. The WSB method is a local method for deciding whether the trajectories about one of the primaries exhibit some kind of stability in terms of the return to a surface of section. The conclusion of this paper, corroborated with the results in [6, 4], is that in simple models the two methods overlap for a substantial range of parameters.

One can think of some other kinds of indicators that mark the passage between the weakly n -stable and the weakly n -unstable regimes. One such a possible indicator is the continuity of the Poincaré return map. The n -th return map to S_{θ_0} is continuous

at all weakly n -stable points. At the WSB points, the return map exhibits essential discontinuities of infinite type. Thus, the set of points where the return map fails to be continuous contains the WSB points.

REFERENCES

- [1] Belbruno, E.: Lunar capture orbits, a method for constructing EarthMoon trajectories and the lunar GAS mission. Proceedings of AIAA/DGLR/JSASS Inter. Propl. Conf. AIAA paper No. 87-1054 (1987)
- [2] Belbruno, E., Miller, J.: A ballistic lunar capture trajectory for the Japanese spacecraft hiten. Jet Propulsion Laboratory, IOM 312/90.41371-EAB (1990)
- [3] Belbruno, E.: Capture Dynamics and Chaotic Motions in Celestial Mechanics. Princeton University Press, 2004.
- [4] Belbruno E., Gidea M., Topputo F.: Weak Stability Boundary and Invariant Manifolds. SIAM Journal on Applied Dynamical Systems, Vol. 9, 2010.
- [5] Conley C.C. and Easton R.W.: Isolated invariant sets and isolating blocks. Trans. AMS, 158, 1, 3560 (1971)
- [6] García, F. and Gómez, G.: A Note on Weak Stability Boundaries. Celestial Mechanics and Dynamical Astronomy **97**, 87–100 (2007)
- [7] Gidea M. and Masdemont J.J.: Geometry of Homoclinic Connections in a Planar Circular Restricted Three-Body Problem. International Journal of Bifurcation and Chaos **17** 1151–1169 (2007)
- [8] Lemonick, M.D.: Spacecraft Twins Arrive at the Moon. Time Magazine, January 01, 2012, <http://www.time.com/time/health/article/0,8599,2103466,00.html>.
- [9] Llibre, J., Martínez, R., and Simó, C.: Transversality of the Invariant Manifolds Associated to the Lyapunov Family of Periodic Orbits near L_2 in the Restricted Three-Body Problem. Journal of Differential Equations **58**, 104–156 (1985)
- [10] McGehee, R.P.: Some homoclinic orbits for the restricted three-body problem. Ph.D. Thesis, University of Wisconsin, 1969.
- [11] Sousa Silva, P.A. and Terra, M.O.: Diversity and Validity of Stable-Unstable Transitions in the Algorithmic Weak Stability Boundary. Preprint, 2011.
- [12] Sousa Silva, P.A. and Terra, M.O.: Applicability and dynamical characterization of the associated sets of the Algorithmic Weak Stability Boundary in the lunar SOI. Preprint, 2011.
- [13] Topputo, F. and Belbruno, E.: Computation of the Weak Stability Boundaries: Sun-Jupiter System. Celestial Mechanics and Dynamical Astronomy, vol. 105, no. 1, 3–17 (2009)

COURANT INSTITUTE OF MATHEMATICAL SCIENCES, NEW YORK UNIVERSITY, NEW YORK, NEW YORK 10003

E-mail address: `belbruno@cims.nyu.edu`

SCHOOL OF MATHEMATICS, INSTITUTE FOR ADVANCED STUDY, PRINCETON, NJ 08540, USA, AND DEPARTMENT OF MATHEMATICS, NORTHEASTERN ILLINOIS UNIVERSITY, 5500 N. ST. LOUIS AVENUE, CHICAGO, IL 60625, USA

E-mail address: `mgidea@neiu.edu`

AEROSPACE ENGINEERING DEPARTMENT, POLITECNICO DI MILANO, VIA LA MASA, 34, 20156, MILAN, ITALY

E-mail address: `topputo@aero.polimi.it`